

# **NATURAL AND ARTIFICIAL AGEING OF AN ALKYD BASED WOOD FINISH**

## **Calorimetric investigations**

*L. Podgorski, A. Merlin\* and J. M. Saiter\*\**

Centre Technique du Bois et de l'Ameublement, 10, avenue de Saint Mandé, 75012 Paris, France

\*Laboratoire de Photochimie Appliquée, BP 239, 54506 Vandoeuvre, Cedex France

\*\*LECAP, BP 118-76134, Mont-Saint-Aignan, Cedex France

### **Abstract**

Wood protection in exterior use is generally achieved with a stain. This protective product is often obtained from an alkyd resin. A natural and artificial ageing have been studied by measuring the glass transition temperature ( $T_g$ ) of the finish variations in terms of time. In both ageings, the  $T_g$  variations are the same; there is an increase in  $T_g$  during the first steps of ageing and then a stabilization. A behaviour equation is proposed and is perfectly suitable to both ageings. Time constants are calculated. This equation shows that the artificial ageing machine chosen is a good means of artificial ageing. It allows the reproduction and the acceleration by 10 times of phenomena which are observed during the natural ageing.

**Keywords:** ageing, alkyd resin, glass transition temperature, wood

### **Introduction**

Wood finish in exterior use is generally achieved with a stain. This is often an alkyd resin based product. Nowadays, only natural ageing tests can give an answer to wood finish system durability. So, such an ageing has been studied. Speedy tests exist. They are usually carried out on several machines which reproduce more or less exactly the climatic conditions to which wood finish system is exposed. These machines are often built on empiric basis. We also have studied such an ageing which has been carried out on a degradations wheel. This machine was built in CTBA. Ageing studies are often based on just visual observations. The results show that it is very difficult to find a link between the natural ageing and the artificial ageing. So, in an objective attempt, we have measured the glass transition temperature ( $T_g$ ) of the finish to observe the polymer evolution during both ageings. Indeed, previous results have shown that  $T_g$  measurement by Differential Scanning Calorimetry (DSC) was an interesting

method to follow finish products ageing [1]. Then, we will try to compare the artificial ageing to the reference ageing which is the natural ageing.

## Experimental

### *Materials and methods*

Three wood species have been studied: oak, lauan and moabi. Wood samples were coated with an alkyd stain (dry extract = 58%). Three coats were applied at the rate of  $130 \text{ g/m}^2$ . A demonstration of natural ageing were carried out at the CTBA on the Fontainebleau site. Samples are held at 1 m from the ground on  $45^\circ$  sloped frames which are facing west-south, as shown in Fig. 1. These frames were built so that the samples could receive the highest amount of sunlight and rain. Then samples are analysed by DSC after 1, 2, 3, 6, 9 and 12 exposure months. Artificial ageing was carried out on the CTBA degradations wheel, as shown in Fig. 2. Samples are held on the wheel and undergo 1 h 30 cycles. One cycle is made of 12 min in distilled water, 27 min at ambient atmosphere, 24 min under 6 UV-lamps, and 27 min at ambient atmosphere. Then samples are analysed at different times of exposure. Finish product is cut off with a scalpel and analyzed by DSC on a DSC 101 SETARAM machine.  $T_g$  is measured from the change of direction of the endothermal signal (heating rate =  $5 \text{ deg}\cdot\text{min}^{-1}$ ).

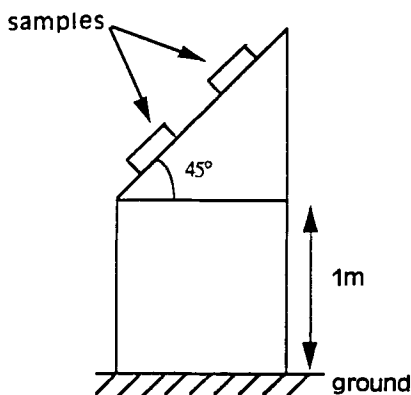

Fig. 1 Frames used for natural ageing

Figure 3 presents the finish  $T_g$  evolution on the three wood species. An increase of  $T_g$  during the first ageing months and then a stabilization to about  $25^\circ\text{C}$  can be observed. The  $T_g$  variations are the same for oak, lauan and moabi. Figure 4 presents results obtained from the degradations wheel. An increase of  $T_g$

during the first ageing hours and then a stabilization to about 23 to 25°C according to the wood species can also be observed.

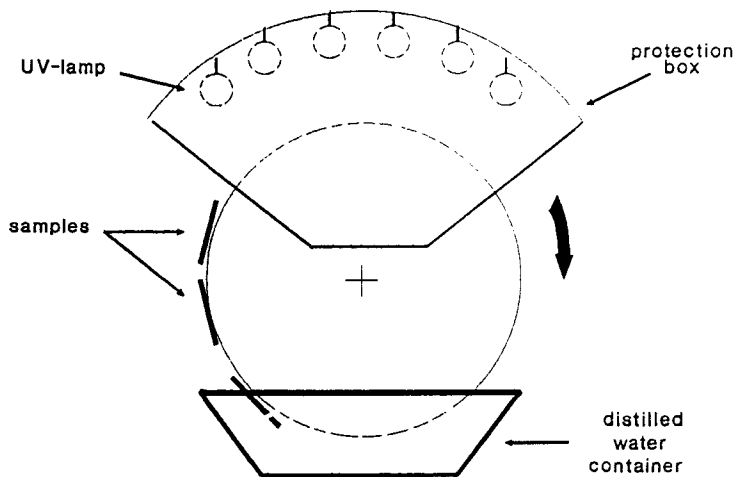

Fig. 2 CTBA degradations wheel

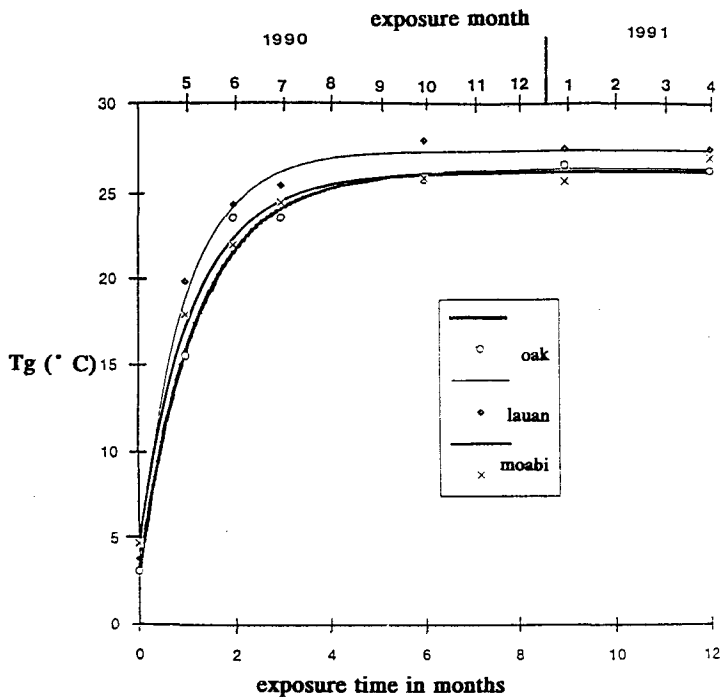

Fig. 3 T<sub>g</sub> evolution during the natural ageing

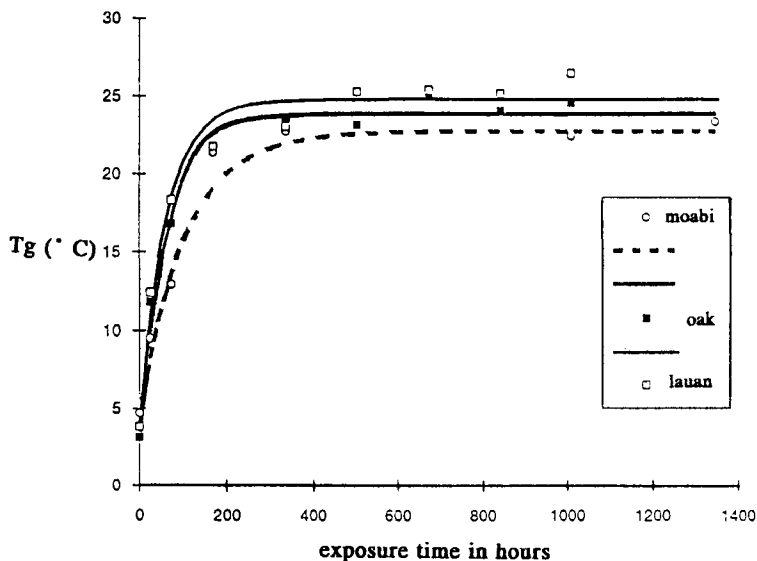

Fig. 4  $T_g$  evolution during the artificial ageing

## Analysis

$T_g$  variations are the same as far as natural and artificial ageing are concerned. These are typical of an exponential increase towards a limited value. In order to describe  $T_g$  variations in terms of time, the following equation can be used [2]:

$$T_{g(t)} = T_{g0} + T_{g1} (1 - \exp^{-t/\tau})$$

with  $T_g = T_{g0}$  when  $t = 0$

$$T_g \rightarrow T_{g\infty} = T_{g0} + T_{g1} \text{ when } t \rightarrow \infty$$

So  $T_{g0}$ ,  $T_{g1}$ ,  $T_{g\infty}$  and  $\tau$  have been calculated for both ageings. The results appear in Table 1.

This table shows that  $T_g$  reaches a maximal value (about 26°C) during natural ageing. It seems that there are no chemical degradations of the polymer since there is no  $T_g$  decrease. Due to UV radiations and oxygen action the polymer goes on crosslink: this is why a  $T_g$  increase appears. Thus, using the glass transition temperature in order to observe the resin evolution during ageing, it is possible to have indications about the resin crosslinking degree.

**Table 1** Typical values of  $T_g$  variations

Ageing	Wood species	$T_{g0}$ / °C	$T_{g1}$ / °C	$T_{g\infty}$ / °C	$\tau$ / h
Natural	Oak	3.1	23.2	26.3	909
	Lauan	3.8	23.6	27.4	714
	Moabi	4.7	21.5	26.2	833
Artificial	Oak	3.1	20.8	23.9	60
	Lauan	3.8	21.0	24.8	60
	Moabi	4.7	18.1	22.8	107

During artificial ageing, the  $T_g$  maximal value is about 24°C. This average is comparable to those obtained during natural ageing. So the degradations wheel allows the reproduction of  $T_g$  variations which can be observed during the natural ageing. Concerning the natural ageing, time constants are very similar for each wood species. The average value is about 800 h. Concerning the artificial ageing, the average time constant is about 75 h. So the degradations wheel allows the acceleration by about 10 times of the phenomena which are observed during the natural ageing.

## Conclusion

The natural and artificial ageing of a wood finish system has been studied by measuring the glass transition temperature ( $T_g$ ) of the finish. It appeared that  $T_g$  variations during both ageings were the same. A behaviour equation has been submitted and shows that the degradations wheel is a good mean of reproduction and acceleration of the obtained  $T_g$  variations during the natural ageing. This is not the case for other types of artificial ageing machines [3].

## References

- 1 H. Nicole, R. Wozniak and M. L. Roux, Congrès AFCAT, Calorimétrie et analyse thermique, Lille, 24–26 mai, vol XIX, (1988), C11.1–C11.7.
- 2 M. H. Schneider and A. R. Sharp, J.C.T., 54, 693, (1982) 91–4.
- 3 L. Podgorski 'Caractérisation d'un système bois-finition: étude du support bois, de la résine et du vieillissement du système complet' Doctorat Sciences du Bois, Université de Nancy I, France, (1993).

**Zusammenfassung** — Der Holzschutz für den Freilufteinsatz wird im allgemeinen durch eine Holzbeize erreicht, welche oft aus einem Alkydharz gewonnen wird. Durch Messung des Glasumwandlungspunktes ( $T_g$ ) der endgültigen Änderung als Funktion der Zeit wurde der natürliche und künstliche Alterungsprozeß untersucht. In beiden Alterungsprozessen sind die  $T_g$ -Änderungen die gleichen; es gibt ein Ansteigen des  $T_g$  während des ersten Alterungsschrittes, gefolgt von

einer Stabilisierung. Es wird eine Verhaltensgleichung vorgeschlagen, die sich für beide Alterungsprozesse ausgezeichnet eignet. Die Zeitkonstanten wurden berechnet. Diese Gleichung zeigt, daß die gewählte Apparatur für die künstliche Alterung ein geeignetes Mittel zur künstlichen Alterung darstellt und die Reproduzierbarkeit sowie auch die Beschleunigung um das Zehnfache der beim natürlichen Alterungsprozeß beobachteten Erscheinungen erlaubt.